

PRODUCT INFORMATION PACKET

Model No: 056T17D11049
Catalog No: G047A
1/3, 1725, DP, 56, 3/60/230/460
Open Drip Proof (ODP)



Regal and Marathon are trademarks of Regal Beloit Corporation or one of its affiliated companies.
©2018 Regal Beloit Corporation, All Rights Reserved. MC017097E



Nameplate Specifications

Output HP	0.33 Hp	Output KW	0.25 kW
Frequency	60 Hz	Voltage	230/460 V
Current	1.2/0.60 A	Speed	1725 rpm
Service Factor	1.35	Phase	3
Efficiency	73.4 %	Duty	Continuous
Insulation Class	B	Design Code	B
KVA Code	M	Frame	56
Enclosure	Drip Proof	Overload Protector	No
Ambient Temperature	40 °C	Drive End Bearing Size	6203
Opp Drive End Bearing Size	6203	UL	Recognized
CSA	Y	CE	Y
IP Code	22		

Technical Specifications

Electrical Type	Squirrel Cage Inverter Rated	Starting Method	Line Or Inverter
Poles	4	Rotation	Reversible
Mounting	Rigid base	Motor Orientation	Horizontal
Drive End Bearing	Ball	Opp Drive End Bearing	Ball
Frame Material	Rolled Steel	Shaft Type	NEMA 56
Overall Length	11.22 in	Frame Length	7.25 in
Shaft Diameter	0.625 in	Shaft Extension	1.97 in
Assembly/Box Mounting	F1 Only		
Outline Drawing	A-SS404127-725	Connection Diagram	A-EE7308-REGAL

This is an uncontrolled document once printed or downloaded and is subject to change without notice. Date Created: 07/02/2018

SS404127

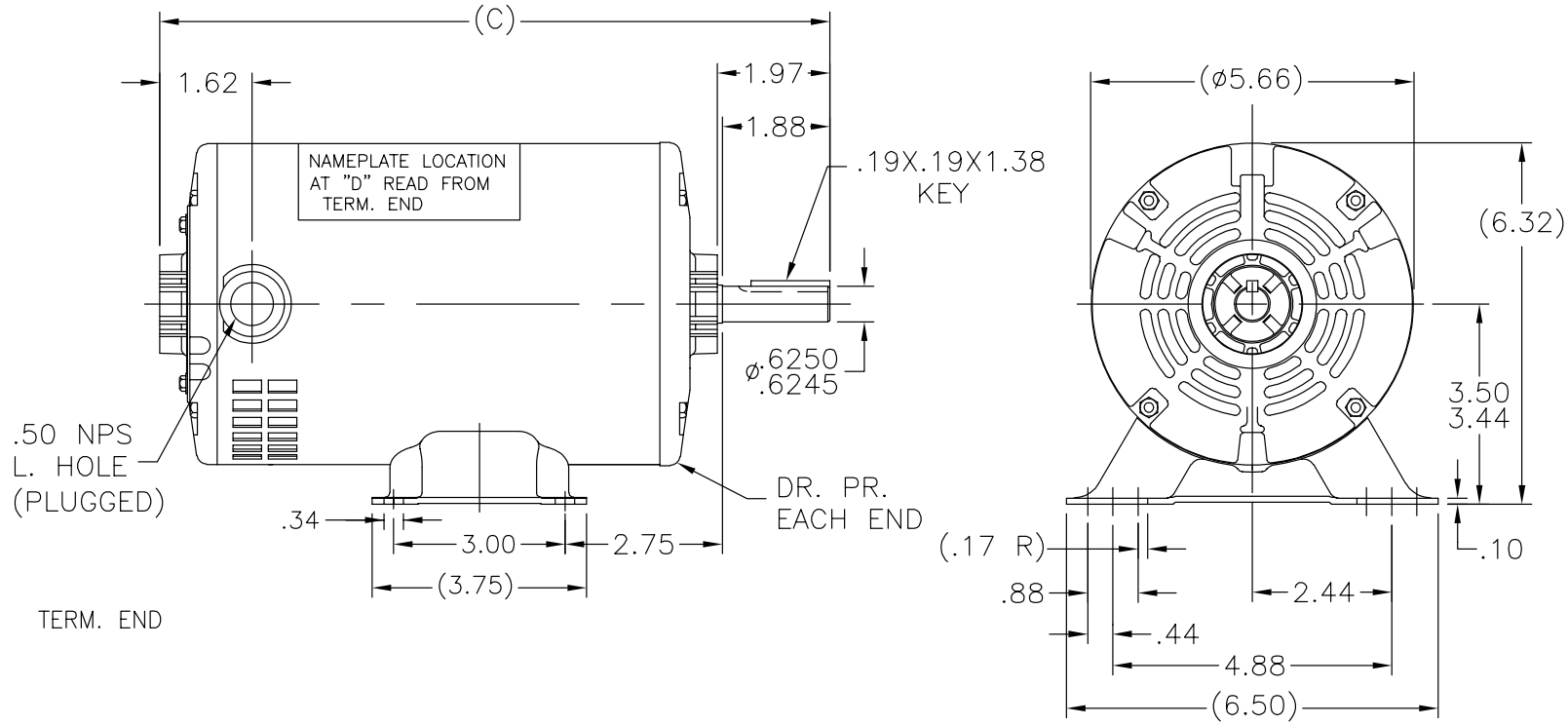

DASH	C	DASH	C	DASH	C
600	9.97	700	10.97	775	11.72
625	10.22	725	11.22	800	11.97
650	10.47	750	11.47	875	12.72

NO.		REVISION	BY & DATE	CHK	ANG	TOLERANCES UNLESS SPECIFIED	 Regal Beloit America, Inc.	DRAWN	PST	12/19/2014	
						DEC. INCHES			CHK	AP	12/19/2014
						.X ±.1	TITLE OUTLINE 56 FR. - DP. MAT'L. FINISH	APPD			
						.XX ±.03		SCALE	3=8		
						.XXX ±.005		REF			
						.XXXX ±.0005		FMF			
						±7'30"		PREV			
THIS DRAWING IN DESIGN AND DETAIL IS OUR PROPERTY AND MUST NOT BE USED EXCEPT IN CONNECTION WITH OUR WORK ALL RIGHTS OF DESIGN AND INVENTION ARE RESERVED THIS IS AN ELECTRONICALLY GENERATED DOCUMENT - DO NOT SCALE THIS PRINT				RFP		CAD FILE SS404127	SIZE	DRAWING NO.	PAGE	OF	REV.
				DIST	WP		A	SS404127			

EE7308

THREE PHASE
DUAL VOLTAGE MOTOR



VIEW OF TERMINAL END

REF.
WINDING DIAGRAM

T8Y, T2Y, T2BL, T4BX, T2EC, T2G
T6BZ, T2B, T6BL, T4AV, T6B, T4B

OPTIONAL CORD
CONNECTION

L1 — WHITE
L2 — RED
L3 — BLACK

NO.	REVISION	BY & DATE	CHK	ANG	TOLERANCES UNLESS SPECIFIED		FINISH	DRAWN RM 11/20/1990				
					DEC.	INCHES						
5	CHG TO REGAL LOGO	SL 09/10/2015	AB					CHK ML 11/21/1990				
4	REVISED IEC NOTATIONS	MSG 11/15/2011	CMN	.X	±.1			APPD SAS 04/24/2003				
3	ADDED IEC NOTATIONS... (U1), (V1) ETC. MU95194	MSG 5/10/2010	MJS	.XX	±.02			SCALE 1=1				
2	ADDED THE OPTIONAL CORD CONNECTION MU46318	RDH 04/24/2003	DRS	.XXX	±.005		TITLE CONNECTION DIAGRAM 3Ø - DUAL VOLTAGE MOTOR	REF				
1	REDRAWN	RM 11/20/1990		.XXXX	±.0005		MAT'L.	FMF				
					±7'30"			PREV				
THIS DRAWING IN DESIGN AND DETAIL IS OUR PROPERTY AND MUST NOT BE USED EXCEPT IN CONNECTION WITH OUR WORK ALL RIGHTS OF DESIGN AND INVENTION ARE RESERVED THIS IS AN ELECTRONICALLY GENERATED DOCUMENT - DO NOT SCALE THIS PRINT							RFP	CAD FILE ee7308	SIZE A	DRAWING NO. EE7308	PAGE OF 5	REV. 5
							DIST WP					



